

SPEED QUEEN | PROFESSIONAL
Top Load Washer



SW-SWC (coin)

Built for Reliable Performance

The Speed Queen top load washer combines heavy-duty construction with reliable operation proven to stand the test of time. They're designed with less moving parts for one reason: so you'll face fewer maintenance problems and less wear and tear down the road. The equipment provides an advantage on such issues as energy conservation, equipment breakdowns and vandalism. These units are ideal for military, colleges, restaurants, beauty salons and other special business applications.

Features

- Durable stainless steel wash tub
- Extract speed of 710 RPM spins clothes out dryer
- Automatic Balancing Suspension provides the industry's best out-of-balance handling, completing wash cycles without interruption
- Curved four-vane polypropylene agitator provides 210° agitation stroke which delivers superior washability
- Dependable, Eversmooth transmission

(OPL) Rear High Electronic Control

Rear High Electronic Control is designed for durability and easy operation with attractive selection buttons and cycle status indicator lights.

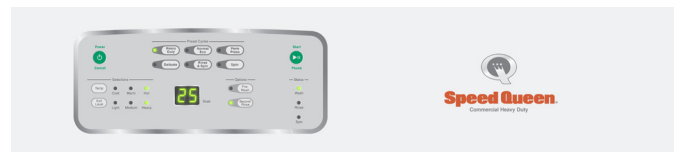

(VEND) Rear Push-To-Start Control

Push-To-Start control provides easy to start activation indicated by "In Use" light.

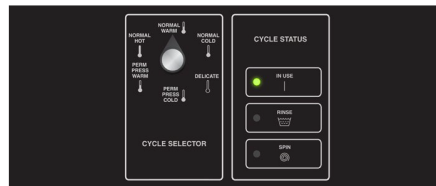

Fast cycles



Large Door Opening



Easy Operation



Low Energy Consumption



Standard Stainless Steel Drum

Washer

Specifications



SW									
	MARKET	ACTUATION	HEATING	VOLTAGE	CONTROL TYPE	CONTROL LOCATION	COLOR	BASKET	DRAIN
LWNE52SP303UW01	Europe/CE	OPL	No heat	230v/50Hz/1N	Electronic (hec)	Rear	White	Stainless	Pump
LWNE52SP303EW01	UK	OPL	No heat	230v/50Hz/1N	Electronic (hec)	Rear	White	Stainless	Pump

Capacity	kg	7,3
Capacity Ratio 1:9	kg	10,5
CONTROL		(OPL) Rear High Electronic Control
		(VEND) Rear Push-To-Start Control
DRUM VOLUME	l	90,3
Spin Speed G-Force (RPM)		150 (710)
MOTOR POWER	kW	0,5
DIMENSIONS		
H×W×D	mm	1092x651x711
Net weight	kg	93,4
TRANSPORT DATA		
Volume (packed)	m ³	0,77
Packed H×W×D		711x762x1143
Gross weight		98,8

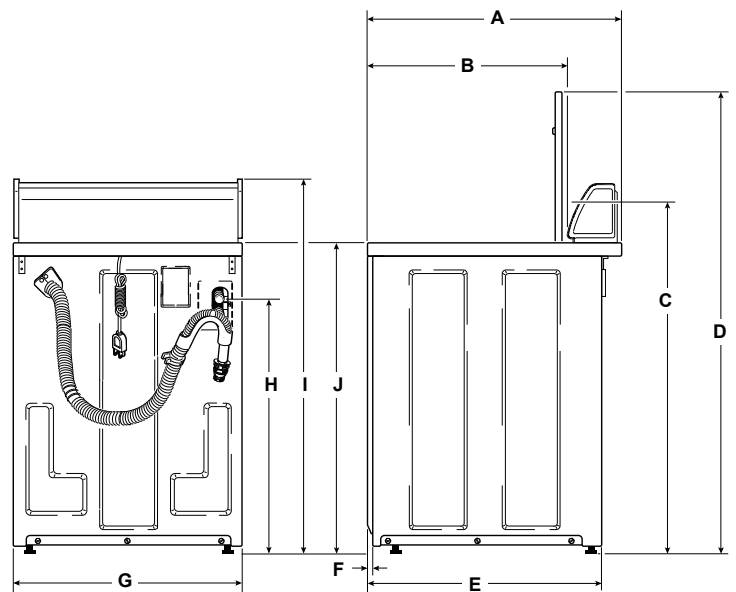

	A	B	C ¹	C ²	D	E	F	G	H	I	J	K	L
mm	548	1377	1092	1114	1026	711	660	11	914	1048	730	651	775

¹ Standard Capacity Meter Case

² High Capacity Meter Case



Washer

Specifications

SWC (coin)										
	MARKET	ACTUATION	HEATING	VOLTAGE	CONTROL TYPE	CONTROL LOCATION	COLOR	BASKET	DRAIN	
	SWNSX2SP303EW01	UK	Prep for coin slide	No heat	230v/50Hz/1N	Push-to-start	Rear	White	Stainless	Pump

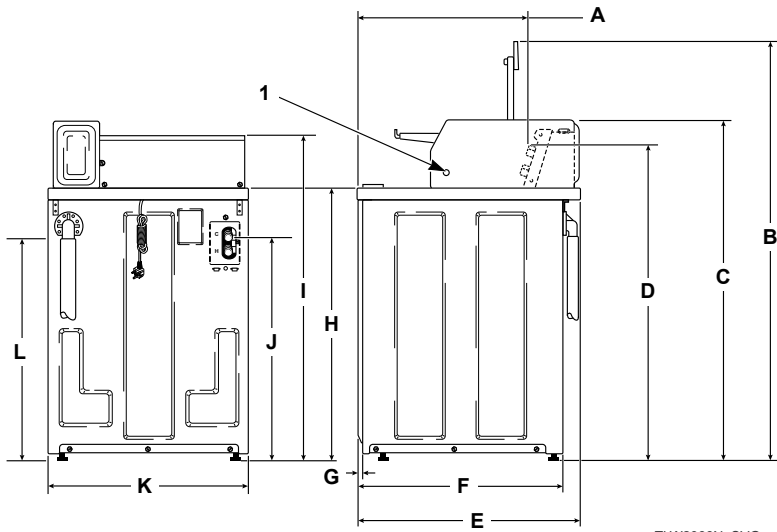

TLW2066N_SVG

	A	B	C ¹	C ²	D	E	F	G	H	I	J	K	L
mm	548	1377	1092	1114	1026	711	660	11	914	1048	730	651	775

¹ Standard Capacity Meter Case

² High Capacity Meter Case

