

# Tumble dryer

## TD6-7



**Dryer featuring exceptional savings and effortless use**



### Priority on people

Certified ergonomic design with a human-centered approach for an outstanding user experience

- Lint filter  
The horizontal filter drawer is positioned for easy access and cleaning without the need to bend down when stacked on a WH6-6
- The display can easily be moved to the bottom of the tumble dryer for a better position when stacked



### Long-term savings

Innovative features to save money and time, and embrace a sustainable lifestyle



### Pure control

Monitor your equipment and performance from anywhere, allowing to take action and to improve your business with OnE Laundry - the personal assistant for hygiene validation management, process management and revenue management (optional)



### Outstanding productivity

Dry more laundry in less time: a game-changing improvement

- Reversing drum  
Minimizes wrinkles and drying time to get an effective and even drying performance



### Global Advanced Hygiene

Global Advanced Hygiene program package\* with proven log 6 reduction\*\* disinfection of textiles through the laundry process, fulfilling the criteria of all local approved standards

### Main options and accessories

- Insulated glass door keeps the door cool on the outside and heat on the inside, so the room temperature is not affected
- Lagoon Advanced Care
- Door, front and side panels are available in stainless steel
- Connectable to booking-/payment system or coin meter
- Stacking kit
- Moisture Balance  
Helps to stop the drying process at the right time to save on energy costs



Images shown are a representation of the product only and variations may occur.  
To get the door design you need to add the insulated glass.

\* Programs available in the standard library of all products, excluding products for specific segments where water temperature is not controllable.

\*\* Log 6 reduction equals to 99,9999% viral infectivity reduction. The efficacy of reduction of SARS-CoV-2 and other pathogens in the process is confirmed by RISE (The Research Institute of Sweden) on the basis of Electrolux Professional laboratory data.

Main specifications			TD6-7			
Rated capacity, filling factor 1:18		kg/lb	7.5/16.5			
	filling factor 1:22	kg/lb	6.1/13.4			
Drum volume		litre	135			
Drum diameter		mm	575			
Heating,	electric	kW	3.0/4.5/6.0			
	gas	BTU/h (kW)	23900 (7.0)			
<b>Consumption data*</b>			EI 3.0 kW	EI 4.5 kW	EI 6.0 kW	Gas
Total time full load		min	57	40	30	30
Energy consumption full load		kWh	3.11	3.11	3.04	3.67
Evaporation		g/min	54	78	104	101
Energy kWh/litre water evaporated		kWh/l	1.01	1.01	0.99	1.20

\* At rated capacity 1:22, 100% cotton load at 50% initial moisture dried to 0%.

Electrical connections					
Heating alternative	Main voltage		Heating power kW	Total power kW	Recommended fuse A
		Hz			
Electric heated	220-240V 1 -	50/60	3.0/4.5/6.0	3.3/4.8/6.3	16/25/32
	220-230V 3 -	50/60	4.5/6.0	4.8/6.3	16/20
	240V 3 -	50/60	4.5/6.0	4.8/6.3	16/16
	380-400V 3 -	50/60	4.5/6.0	4.8/6.3	10/10
	415/440/480V 3 -	60	4.5/6.0	4.8/6.3	10/10
Gas heated	220-480V 1/3 -	50/60	*	0.3	10

\* Total power and recommended fuse does not depend on the heating power in those cases.

Gas and air connections			TD6-7
Gas		ISO 7/1-R	1/2"
Gas pressure	Natural gas	Pa	2000
		mbar	20
	Propane	Pa	2800-5000
		mbar	28-50
Air outlet		Ø mm	125
Evacuated air,	el 3.0/4.5 kW	m <sup>3</sup> /h	150
		m <sup>3</sup> /h	220
Pressure drop	gas 7.0 kW		280
		el 3.0/4.5 kW	Max. Pa
	6.0 kW	Max. Pa	270
	gas 7.0 kW		230
Sound levels			
Sound power/pressure level at drying*		dB(A)	63/48
Heat emission			
% of installed power, max			15
Shipping data**			
Weight		kg	109
Shipping volume		crated, m <sup>3</sup>	0.81
Dimensions in mm			
A	Width		600
B(a)	Depth, el		845
B(b)	Depth, gas		875
C	Height		1050
D			580
E			385
F			80
G			80
H			50
I			100
J			120
K			90
L			520
1	Operating panel		
2	Door opening Ø 392 mm		
3	Electrical connection		
4	Exhaust connection		
5	Gas connection		

Front and side panels in silver grey and dark blue (color samples can be ordered on part number 472998313).

\* Sound power levels measured according to ISO 60704.

\*\* Average data. Crated weight/shipping volume depends on configuration. Please contact logistics for exact measures.

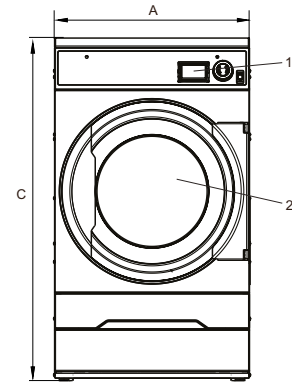

Front

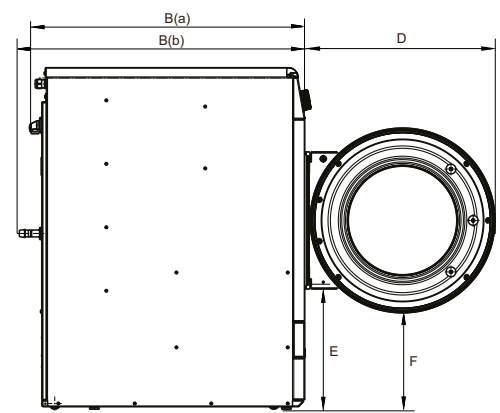

Left side

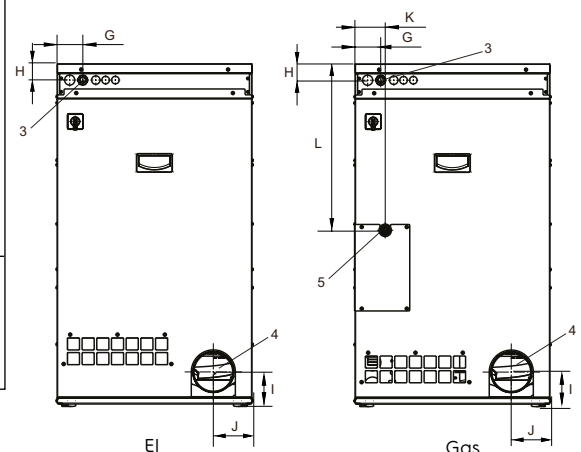

Rear side