

Barrier washers

Hyvolution range

WHB5500H

Features and benefits

- Two compartments drum with Pullman split, offering the best ergonomics and mechanical action
- Automatic inner drum positioning for fast and effortless loading and unloading operations
- Automatic outer door locking and unlocking with pneumatic system for maximum easiness and safety
- The largest inner drum door on the market, making loading and unloading operations fast and easy
- Silent operations and extraction management through the Electrolux patented Power Balance system
- Available in electrical, steam, gas or dual heating with steam and electrical
- Compass Pro control panel for a fast and easy selection of the wash program

Main options

- Automatic inner drum door opening at the end of the cycle for effortless and fast unloading operations
- Dual display (on the unloading side)
- Titration valve for decontamination and pH measurements
- Third water inlet for soft or recycled water
- Second drain for water reuse
- Detergent box for manual injection
- Stainless steel panels
- Clarus TS control panel (Touch Screen)
- Integrated weighing system to optimize loading operations



Images shown are a representation of the product only and variations may occur.

Main specifications				WHB5500H		
Max. capacity	filling factor 1:10	kg/lb		50/110		
Drum,	volume	litre		500		
	diameter	ø mm		920		
Extraction		rpm		825		
G-factor				350		
Heating alternatives, 380-400V	electricity	kW		36.0		
	steam	kg/h		24.5		
	gas	kW		40		
Consumption data "Cotton eco" *				El	Steam	Gas
Water consumption (cold)		litre		542	542	562
Energy consumption (motor/heating)		kWh		11	1.2	1.2
Steam consumption		kg		-	24.5	-
Gas consumption		kW		-	-	40
Compressed air consumption		litre		<10	<10	<10

* With accordance to ISO 93 98 -4 prog C.

Produced according to ISO 9001 and ISO 14001.

Certified with CB certificate for Low Voltage Directive and according to the Machinery Directive. Protection class IP X4D.

Electrical connections					
Heating alternative	Main voltage		Heating power kW	Total power kW	Recommended fuse A
	Hz	Hz			
WHB5500H					
Electric heated	400-415V 3 ~	50/60	36	42	3 x 63
Steam heated	400-415V 3 ~	50/60	-	6	3 x 16
Gas heated	400-415V 3 ~	50/60	40	6	3 x 16
Non heated	400-415V 3 ~	50/60	-	6	3 x 16

Water, steam, gas and air connections		WHB5500H
Water valves	DN	20
Water pressure	kPa	50-600
Capacity at 250 kPa	l/min	70
Drain valve	∅ mm	75
Draining capacity	l/min	240
Steam valve	DN	20
Steam pressure	kPa	300-600
Gas valve	DN	20
Fumes exhaust	mm	60
Compressed air	mm	6/8
Compressed air pressure	kPa	450-600
Floor requirements		
Frequency of the dynamic force	Hz	13.75
Sound levels		
According to EN50571: 2013, annex CC		
Wash	dB(A)	64
Extraction	dB(A)	83
Heat emission		
% of installed power, max		3
Shipping data*		
Shipping weight	net, kg	1170
Shipping weight	gross, kg	1280
Shipping volume	m ³	4.73
Dimensions in mm		
A	Width	1300
B	Depth	1265
C	Height	1770
D		920
E		40
F		40
G		1385
H		330
I		450
J		570
K		220
L		195
M		80
N		160
O		840
P		670
Q		240
R		70
S		1135
T		635
U		650
V		1560
W		85
X		270
Y		860
Z		2330
1	Control panel	8 Drain
2	Loading door	9 Double drain
3	Detergent container	10 Air vent connection
4	Cold hard water	11 Electrical connection
5	Hot water	12 Compressed air connection
6	Cold soft water	13 Main switch
7	Steam connection	14 Liquid detergent inlet

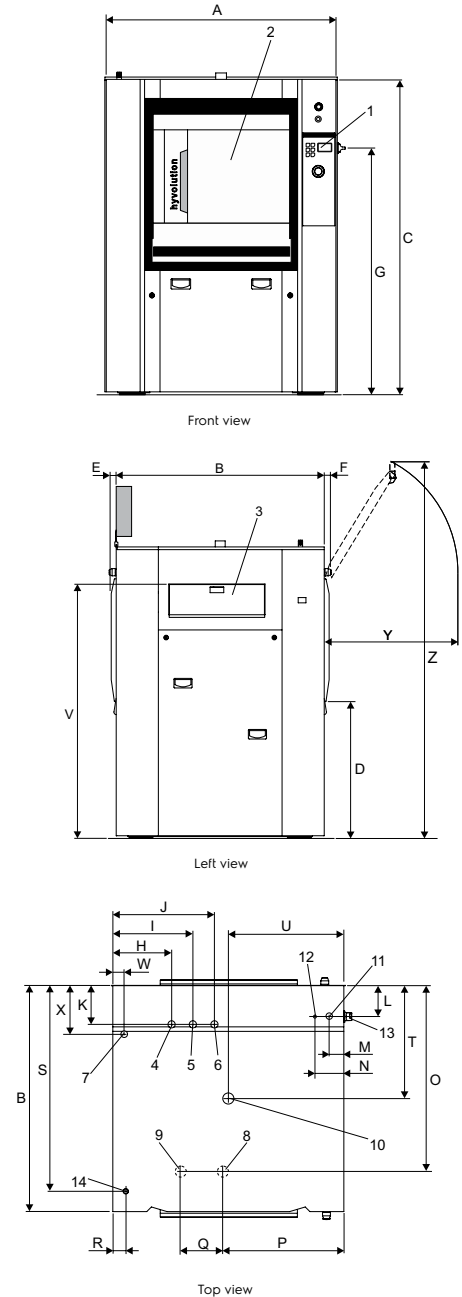

* Average data. Crated weight/shipping volume depends on configuration. Please contact logistics for exact measures.